

M12

Heat-Resistant Inductive Proximity Sensor

Characteristic / 特點 :

- 110 degree C. / 耐高溫110°C內，合適高溫作業。
- Anti-bending design. / 耐彎包覆保護設計。
- Protection rating : IP67. / IP67防水等級。

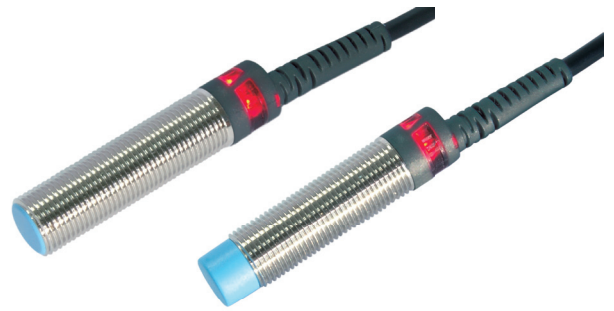

Specifications / 規格表 :

Output method / 輸出模式	NPN N.O	HPS1202-N	HPS1202-ND	HPS1204-N	HPS1204-ND
	NPN N.C.	HPS1202-N2	HPS1202-N2D	HPS1204-N2	HPS1204-N2D
	PNP N.O.	HPS1202-P	HPS1202-PD	HPS1204-P	HPS1204-PD
	PNP N.C.	HPS1202-P2	HPS1202-P2D	HPS1204-P2	HPS1204-P2D
	NPN N.O./N.C. PNP N.O./N.C.	-	-	-	-
Sensing distance / 檢出距離	2 mm			4 mm	
Secure sensing distance / 建議距離	0 to 1.6 mm			0 to 3.2 mm	
Standard sensing object / 標準檢測物	Iron 12 × 12 × 1 mm				
Sensing type / 檢出方式	Shielded / 隔離型			Unshielded / 非隔離型	
Description / 外型	Standard M12 / 標準M12				
Hysteresis / 遲滯	≤ 10 % of sensing distance				
Response time / 反應時間	DC Type 1 ms Max.				
Operating voltage / 工作電壓	DC 12 ~ 24 V or				
Current consumption / 消耗電流	DC: ≤ 14 mA no-load				
Load current / 負載電流	DC: 100 mA Max. at DC 24V				
Leakage current / 漏電流	≤ 1.1 mA no-load				
Residual voltage / 殘餘電壓	≤ DC 2V				
Insulation resistance / 隔離阻抗	20MΩ min. (DC500V)				
Voltage withstandability / 絕緣耐壓	AC1000V 60Hz for 60 Sec.				
Operating temperature / 工作溫度	-20°C ~ + 110°C				
Protection degree / 防水等級	IP 67				
Wiring method / 出線方式	Ø4.2x2M/3-wires	M8 pigtailed type / M8接頭15cm電線式	Ø4.2x2M/3-wires	M8 pigtailed type / M8接頭15cm電線式	
Weight / 重量	Approx. 64g	Approx. 48.4g	Approx. 65g	Approx. 49.4g	

Dimensions / 尺寸圖 : (unit:mm)

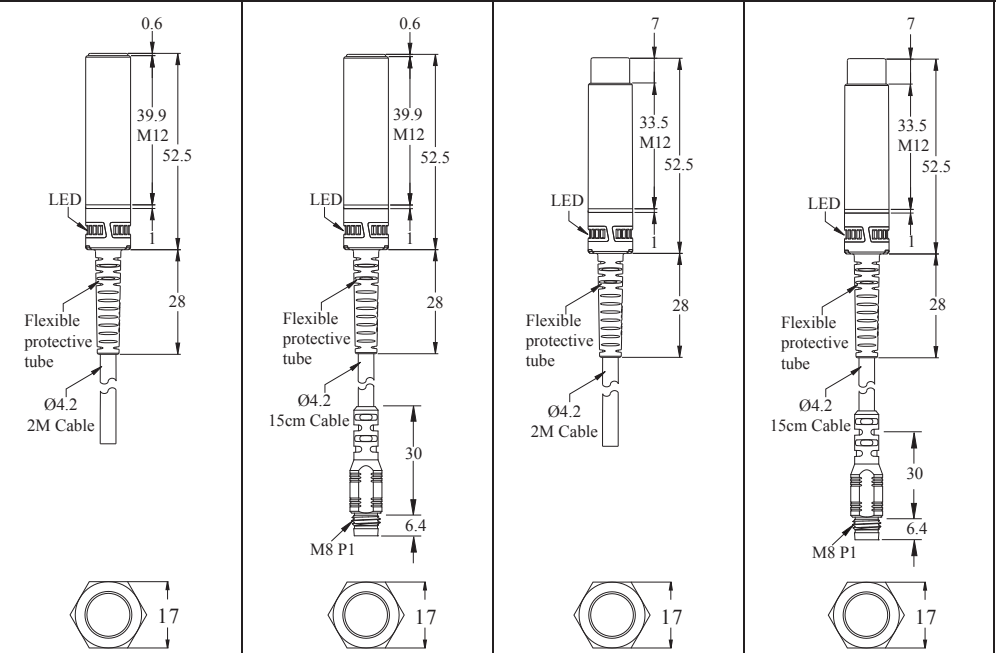

Inductive / Capacitive Proximity Sensor

PSD18-LA/LV
PSC18-LA/LV
SC18-LA/LV

HPD
HPS

Ø4
M5
Ø6
M8
M12
M18
M30

JN
JND
KND
PN
PND
RN
SN
TSN

SID
SIR
SIA

PKC
KC
KCM
KCP