

### ◆ Characteristic / 特點 :

- CW. and CCW. sensing options.  
/ 正向(CW.) 反向(CCW.)掃描, 安裝度自由。
- Big and bright LED output indicator.  
/ 大面積動作指示燈, 清楚明瞭。
- NPN/PNP embedded outputs.  
/ 同時具備NPN/PNP, 方便選擇。
- Innovative 2 types of signal pulse.  
/ 業界首創, 兩段功率調整。

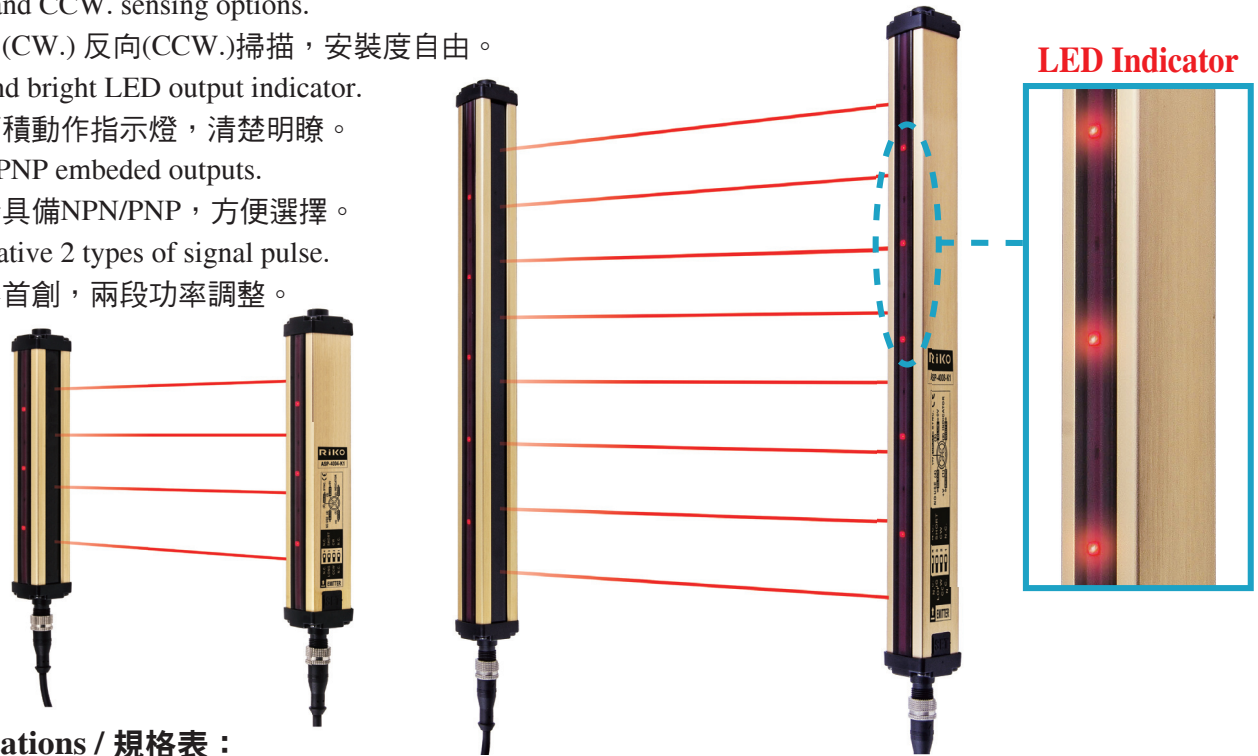

### ◆ Specifications / 規格表 :

Model / 型號	NPN or PNP L.on/D.on	ASP-4004-K1	ASP-4008-K1	ASP-4012-K1	ASP-4016-K1
		ASP-4004S-K1	ASP-4008S-K1	ASP-4012S-K1	ASP-4016S-K1
No.of Beams/光軸數		4	8	12	16
Sensing Height / 檢測高度		120 mm	280 mm	440 mm	600 mm
Beam pitch / 光軸間距		40 mm			
Sensing type / 檢出方式		Through beam / 對照式			
Resolution / 分辨率		60 mm opaque object 不透明物體			
Sensing distance / 檢出距離		0.6 M ~ 5 M 0.3 M ~ 2 M	0.6 M ~ 5 M 0.3 M ~ 2 M	0.6 M ~ 5 M 0.3 M ~ 2 M	0.6 M ~ 5 M 0.3 M ~ 2 M
Emitting light / 發光源		Infrared LED(紅外線發光LED) : 850 nm			
Indicating LED / LED指示燈		Blinking or shining output indicators. 動作指示燈有閃爍式、恆亮式			
Running type / 運轉方式		More than one beam is covered ON ( Dark On ) 任意一個光束被遮斷即輸出			
Operating voltage / 工作電壓		DC12 ~ 24 V±10% (ripple P-P : 10% Max.)			
Current Consumption / 消耗電流		Transmitter : 35 mA Max. Receiver : 30 mA Max.	Transmitter : 45 mA Max. Receiver : 35 mA Max.	Transmitter : 55 mA Max. Receiver : 40 mA Max.	Transmitter : 60 mA Max. Receiver : 40 mA Max.
Load current / 負載電流		100 mA Max. at DC 24V			
Protection circuit / 保護電路		Reversed Supply circuit protection, Short circuit protection output 電源反接保護及輸出短路保護			
Response time / 反應時間		Off to On : 15 ms Max. On to Off : 20 ms Max.			
Insulation resistance / 隔離阻抗		20MΩ min. (DC500V)			
Voltage withstandability / 絕緣耐壓		AC1000V 60Hz for 60 Sec.			
Operating temperature/工作溫度		- 10 °C ~ + 45°C ( No freezing allowed不可結霜,結冰 )			
Ambient humidity / 工作溼度		35% ~ 85% RH 相對溼度			
Storage temperature / 儲存時溫度		- 10 °C ~ + 45°C ( No freezing allowed不可結霜,結冰 )			
Storage humidity / 儲存時溼度		35% ~ 95% RH 相對溼度			
Protection degree / 防水等級		IP62			
Material / 外觀材質		Aluminum+ABS / 鋁+ABS			
Wiring method / 出線方式		Transmitter : M12 pigtailed type(5P) Receiver : M12 pigtailed type(5P)			
Option / 選購配件 (Page 256)		Connectors / 線材 : M125R-PUR-2M / M125R-PUR-5M			
Weight / 重量		Approx.315g	Approx.580g	Approx.875g	Approx.1160g

◆ Dimensions / 尺寸圖 : (unit:mm)

• Emitter/ 發射

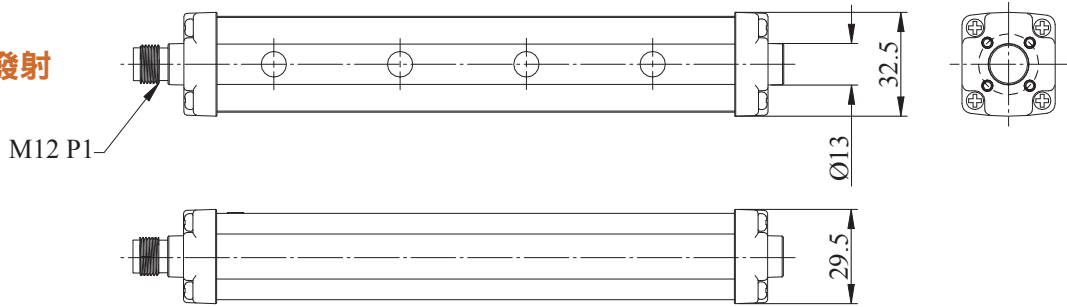

• Receiver/ 接收

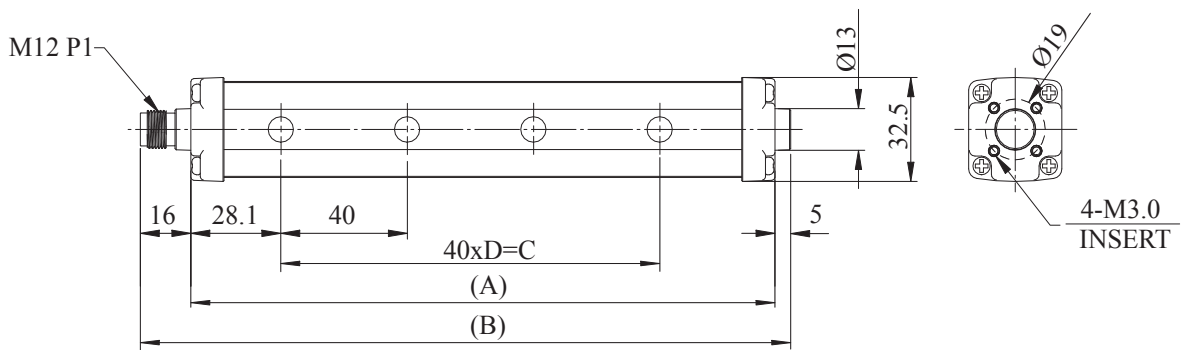

Model	(A)	(B)	(C)	(D)
ASP-4004(S)-K1	184.2mm	205.2mm	120mm	3
ASP-4008(S)-K1	344.2mm	365.2mm	280mm	7
ASP-4012(S)-K1	504.2mm	525.2mm	440mm	11
ASP-4016(S)-K1	664.2mm	685.2mm	600mm	15

• ASP-Bracket / ASP固定架

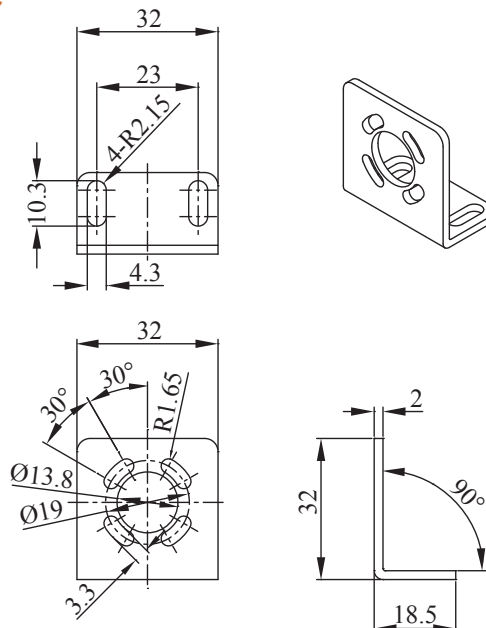

Photo / Area Photo / Ultrasonic Sensor

R5JM /R3JK

PTQ18

PMF /RMF /MMF

PK3 /PK5 /PM6

SU /SU15 /SU07 /SU30

SPR /RX

OAP /ASP

RU18

### ◆ DIP Switch / 指撥開關 :

ASP-4004(S)-K1 / ASP-4008(S)-K1 / ASP-4012(S)-K1 / ASP-4016(S)-K1

#### • Emitter/ 發射

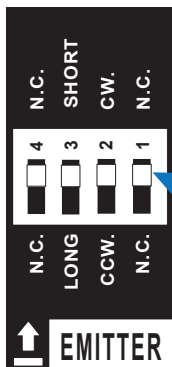

- 4.N.C./N.C.(無功能)
- 3.LONG/SHORT(長/短距)
- 2.CCW./CW.(反/正向掃描)
- 1.N.C./N.C.(無功能)

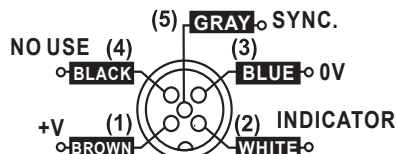

#### • Receiver/ 接收



- 4.NPN/PNP OUTPUT
- 3.CCW./CW.(反/正向掃描)
- 2.FLASH/FIX(閃爍/不閃爍)
- 1.D.ON/L.ON(遮光/入光動作)

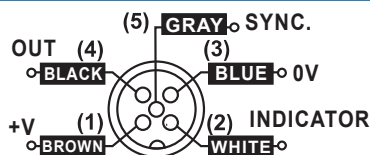

### ◆ Circuit Diagram / 接線圖 :

#### Emitter(發射)

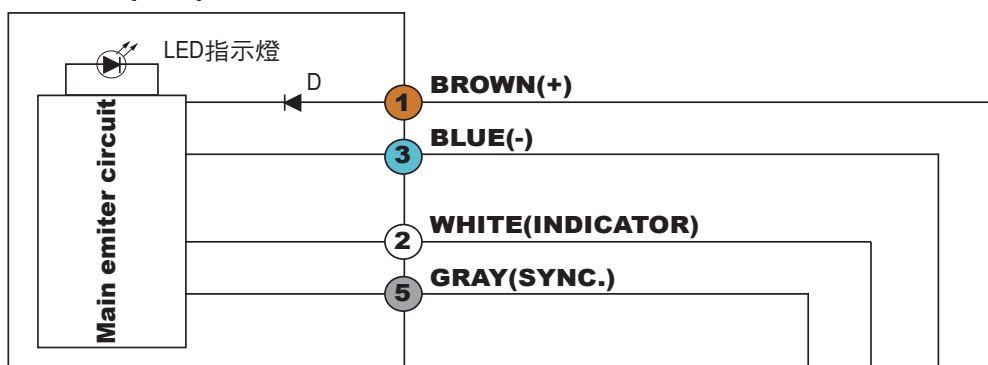

#### Receiver(接收)

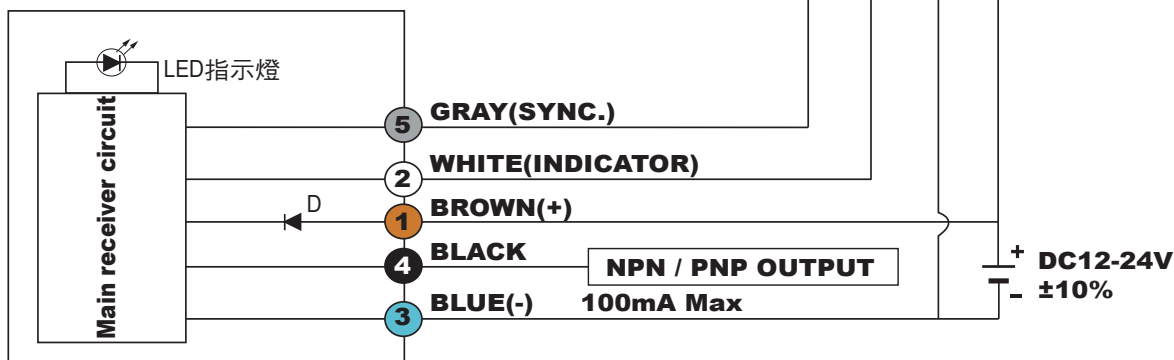

Photo / Area Photo / Ultrasonic Sensor

R5JM /R3JK

PTQ18

PMF /RMF /MMF

PK3 /PK5 /PM6

SU /SU15 /SU07 /SU30

SPR /RX

OAP /ASP

RU18